

Curved Alignment

Changes in direction of sewer lines are usually accomplished at manhole structures. Grade and alignment changes in concrete pipe sewers, however, can be incorporated into the line through the use of deflected straight pipe, radius pipe or specials.

DEFLECTED STRAIGHT PIPE

With concrete pipe installed in straight alignment and the joints in a home (or normal) position, the joint space, or distance between the ends of adjacent pipe sections, is essentially uniform around the periphery of the pipe. Starting from this home position any joint may be opened up to the maximum permissible on one side while the other side remains in the home position. The difference between the home and opened joint space is generally designated as the pull. The maximum permissible pull must be limited to that opening which will provide satisfactory joint performance. This varies for different joint configurations and is best obtained from the pipe manufacturer.

The radius of curvature which may be obtained by this method is a function of the deflection angle per joint (joint opening), diameter of the pipe and the length of the pipe sections.

The radius of curvature is computed by the equation:

$$R = \frac{L}{2 \left(\tan \frac{1}{2} \frac{\Delta}{N} \right)} \quad (1)$$

where:

- R = radius of curvature, feet
- L = length of pipe sections measured along the centerline, feet
- Δ = total deflection angle of curve, degrees
- N = number of pipe with pulled joints
- $\frac{\Delta}{N}$ = total deflection of each pipe, degrees

From Figure 1, the deflection angle $\frac{1}{2} \frac{\Delta}{N}$ is further defined as:

$$\frac{1}{2} \frac{\Delta}{N} = \sin^{-1} \frac{PULL}{2(D + 2t)} \text{ or } \sin^{-1} \frac{PULL}{2B_c} \quad (2)$$

where:

- PULL = joint opening, inches
- D = inside pipe diameter, inches
- t = wall thickness, inches

Figure 1 Deflected Straight Pipe

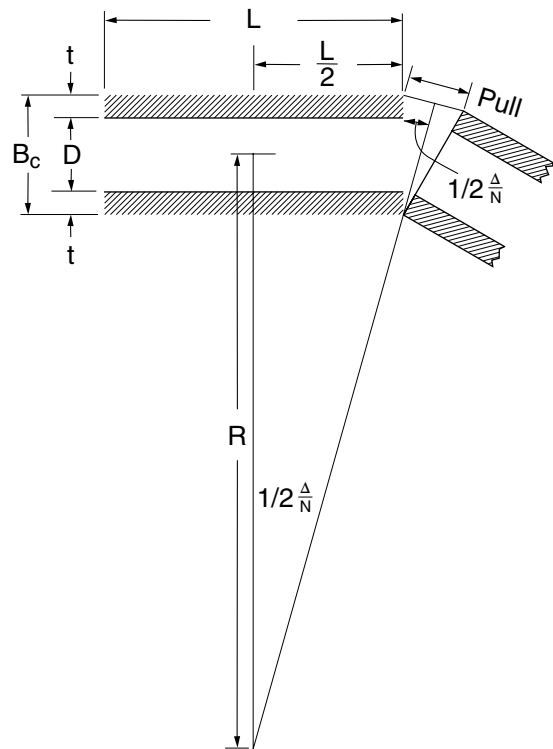
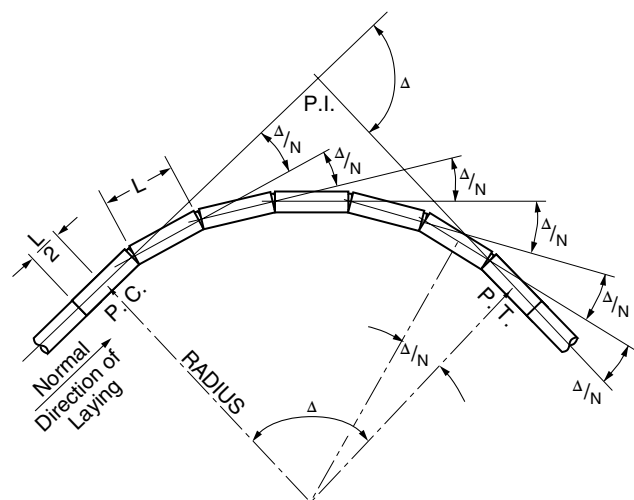

Figure 2 Curved Alignment Using Deflected Straight Pipe



B_c = outside pipe diameter, inches

The joint opening and pipe length required to provide a curved pipeline alignment may be calculated using the unit values found in Table 1 on page 3. The table tabulates the radius of a pipeline constructed of standard eight-foot laying length pipe with a 1/2-inch joint opening (PULL). Other pipeline radii may be calculated by changing, first, the joint opening, and if necessary, the pipe laying length. An eight-foot laying length is standard for most concrete pipe manufacturers. Other lengths may require special manufacturing procedures. Changes in the design radius are directly proportional to the pipe laying length and inversely proportional to the joint opening. The specific pull per pipe joint is found by the equation:

$$PULL_x = \left(\frac{L_x}{L_8} \right) \left(\frac{R_u}{R_x} \right) (PULL_8) \quad (3)$$

$$R_x = (L_x/L_8)(PULL_8/PULL_x) R_u \quad (4)$$

where:

PULL = the joint opening
 R_u = the Unit Radius (Taken from Table 1)
 L_x = Length of deflected pipe

Specific radii may be calculated by the following procedure:

- Select the unit radius of curvature for the specified diameter pipe from the chart.
- Increase or decrease the joint opening (PULL) in Equation 1 to obtain the design radius. If the required joint opening exceeds the pipe manufacturers recommendations, select a pipe with a shorter laying length. Four and six foot are common non-standard pipe lengths. Check with the pipe manufacturer for availability of non-standard lengths.
- Recalculate the pull for the shorter pipe.

As illustrated in Figure 2, when concrete pipe is installed on curved alignment using deflected straight pipe, the point of curve (P.C.) is at the midpoint of the last undeflected pipe section and the point of tangent (P.T.) is at the midpoint of the last pulled pipe.

RADIUS PIPE

Radius pipe, also referred to as bevelled or mitered pipe, incorporates the deflection angle into the pipe joint. The pipe is manufactured by shortening one side of the pipe. The amount of shortening or drop for any given pipe is dependent on manufacturing feasibility. Because of the possibility of greater deflection angles per joint, sharper curvature with correspondingly shorter radii can be obtained with radius pipe than with deflected straight pipe. As in the case of deflected straight pipe, the radius of curvature which may be obtained by radius pipe is a function of the deflection angle per joint, diameter of the pipe, length of pipe sections and wall thickness.

The radius of curvature is computed by the equation:

$$R = \frac{L}{\text{TAN } \frac{\Delta}{N}} - \left(\frac{D}{2} + t \right) \quad (5)$$

where:

Δ = total deflection angle of curve, degrees
 N = number of radius pipe
 L = standard pipe length being used, feet
 $\frac{\Delta}{N}$ = total deflection angle of each pipe

From Figure 3, the radius of curvature can be expressed in terms of the drop and is given by the equation:

$$R = \frac{L(D + 2t)}{\text{DROP}} - \left(\frac{D}{2} + t \right) \quad (6)$$

$$R = B_c \left(\frac{L}{\text{DROP}} - \frac{1}{2} \right) \quad (7)$$

$$\text{DROP} = \frac{LB_c}{R + B_c/2} \quad (8)$$

where:

B_c = outside diameter of the pipe, feet

Figure 5 presents R/B_c ratios for drops from one inch through 15 inches and commonly manufactured pipe lengths. **Since the maximum permissible drop for any given pipe is dependent on manufacturing feasibility, it is essential to coordinate the design of radius pipe with the pipe manufacturer. Many manufacturers have standardized joint configurations and deflections for specific radii and economics may be realized by utilizing standard radius pipe.**

As illustrated in Figure 4, when concrete pipe is installed on curved alignment using radius pipe, the pipe sections are oriented such that the plane of the dropped joint is tangent to the theoretical circular curve. Projection of the joints do not converge at a common point, but are tangents to a common circle of diameter equal to the length of pipe sections. The point of curve (P.C.) is at the midpoint of the last straight pipe and the point of tangent (P.T.) is one half of the standard pipe length back from the straight end of the last radius pipe. The required number of pieces of radius pipe is equal to the length of the circular curve in feet divided by the centerline length of the radius pipe ($L - 1/2 \text{ DROP}$). Where possible, minor modifications in the radius are normally made so this quotient will be a whole number.

Minimum radius of curvature obtained from equations (1) and (5) are approximate, but are within a range of accuracy that will enable the pipe to be readily installed to fit the required alignment. A reasonable amount of field adjustment is possible for radius pipe by pulling the joints in the same manner as with deflected straight pipe.

BENDS AND SPECIAL SECTIONS

Special precast sections can be used for extremely

short radius curves which cannot be negotiated with either deflected straight pipe or with conventional radius pipe. Sharper curves can be handled by using special short lengths of radius pipe rather than standard lengths. These may be computed in accordance with the methods discussed for radius pipe. Certain types of manufacturing processes permit the use of a dropped joint on both ends of the pipe, which effectively doubles the deflection. Special bends, or elbows can be manufactured to meet any required deflection angle and some manufacturers produce standard bends which provide given angular deflection per section.

One or more of these methods may be employed to meet the most severe alignment requirements. **Since manufacturing processes and local standards vary, local concrete pipe manufacturers should be consulted to determine the availability and geometric configuration of special sections.**

The following example illustrates proper use of the Tables and Figures.

Given: A 42-inch diameter concrete pipe storm sewer is to be installed on curved alignment corresponding to the roadway curvature. The pipe will be manufactured in 7-1/2 foot lengths with a 4-1/2-inch wall thickness. The curve data for the roadway curb is:
 point of intersection station P.I. = 50+00
 point of curve station P.C. = 49+29.6
 point of tangent station P.T. = 50+63.1
 total deflection angle Δ = 45°
 radius of curvature R = 170 feet

Find: The required pull per joint for deflected straight pipe or the required drop for radius pipe.

Solution: From Table 1, for a 42-inch diameter pipe, the radius of curvature for a 1-inch pull is 408 feet. The required pull for 170 feet is:

$$PULL_x = \left(\frac{7.5}{8}\right) \left(\frac{408}{170}\right) (1) = 1.125''$$

To evaluate the required drop for radius pipe to negotiate the roadway curvature, it is first necessary to calculate the R/Bc ratio:

$$\frac{R}{B_c} = \frac{170}{4.25} = 40$$

Enter Figure 5 on the vertical scale at R/Bc 40. Proceed horizontally until the line representing L = 7.5 feet is intersected. At this point the horizontal scale shows the required drop to be 2.2 inches. Or

$$Drop = \frac{(7.5)(4.25)}{170 + 4.25/2} = 0.185 \text{ ft.} = 2.2 \text{ in.}$$

Answer: Radius pipe with a 2-1/4-inch drop would be required. **It is important to consult local concrete pipe manufacturers to determine the feasibility of manufacturing a 42-inch diameter pipe with the required drop.**

Figure 3 Radius Pipe

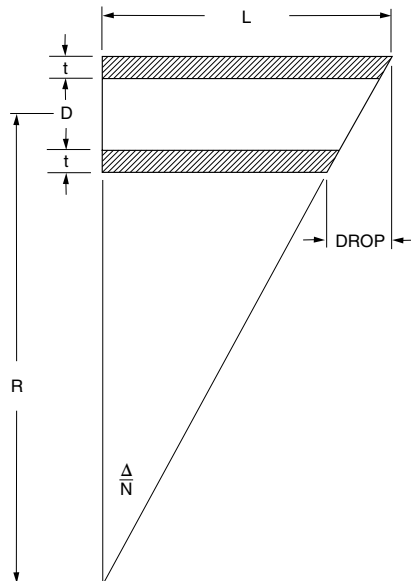

Figure 4 Curved Alignment Using Radius Pipe

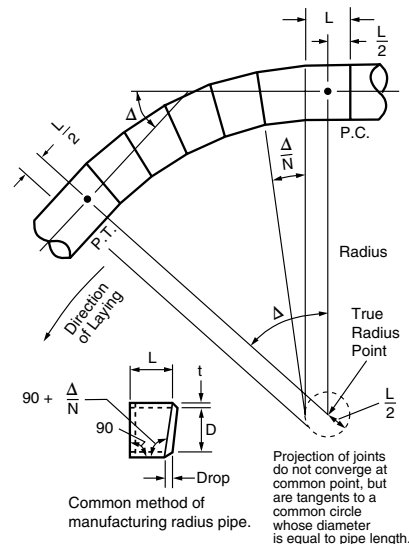

Table 1 Unit Radius of Curvature For 8-Foot Straight Deflected Pipe With 1" Pull

Size	12	15	18	20	24	27	30	33	36	42	48	54	60	66	72	78	84	90	96
Radius	128	156	184	212	240	268	286	364	352	408	464	520	576	632	688	744	780	856	912

Figure 5 Radius of Curvature For Radius Pipe

